

TWO-POST LIFT MODEL: PK10-B

CAPACITY:.....10,000 LBS
 RISE:..... 78"
 MINIMUM CEILING HEIGHT REQ'D:....148"
 MOTOR:.....2 HP
 VOLTAGE OPTION 1:..... 208-230V/1PH
 VOLTAGE OPTION 2:..... 230-460V/3PH

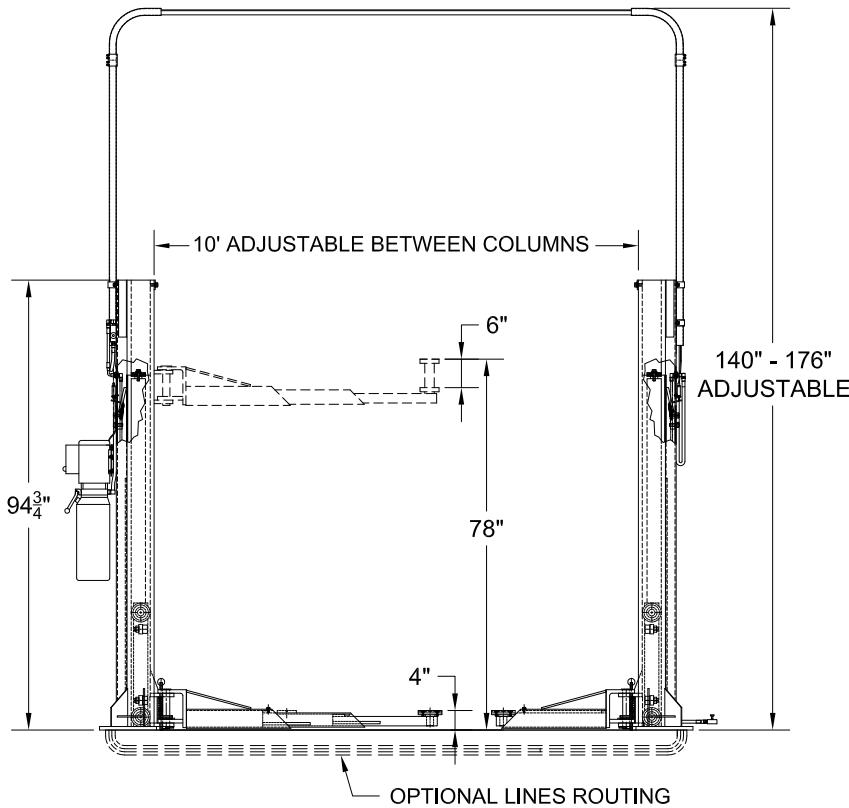

FEATURES:

1. FORK LIFT MAST CHANNEL AND ROLLERS BEARINGS.
2. CLEAR FLOOR FOR EASY ACCESS.
3. NO OVERHEAD BEAM WITH BURIED CONDUIT OPTION.
4. NO EQUALIZING CABLES
5. LOW PROFILE ARMS
6. GEARED ARM RESTRAIN WITH SINGLE POINT LOCK AND RELEASE.
7. THREE STAGE ARMS
8. COMES WITH A SET OF HEIGHT ADAPTERS 3" AND 6" STACK ABLE TO 9".

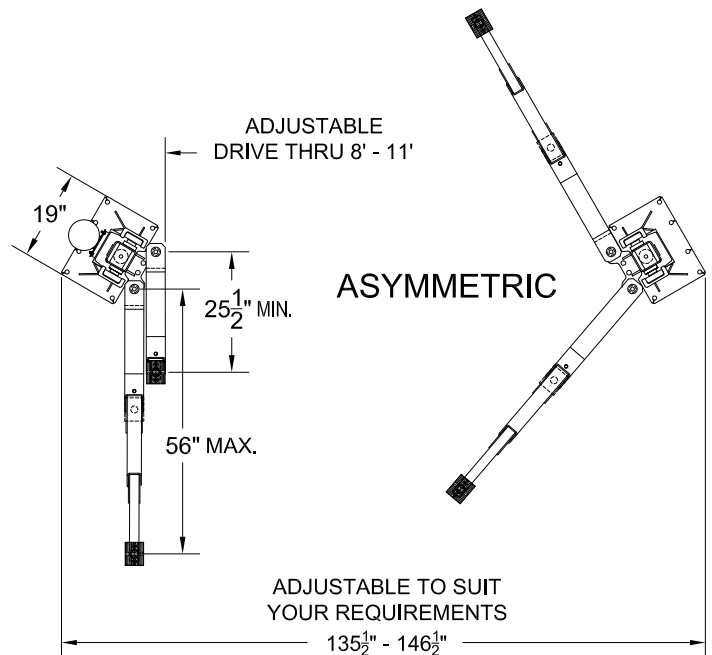
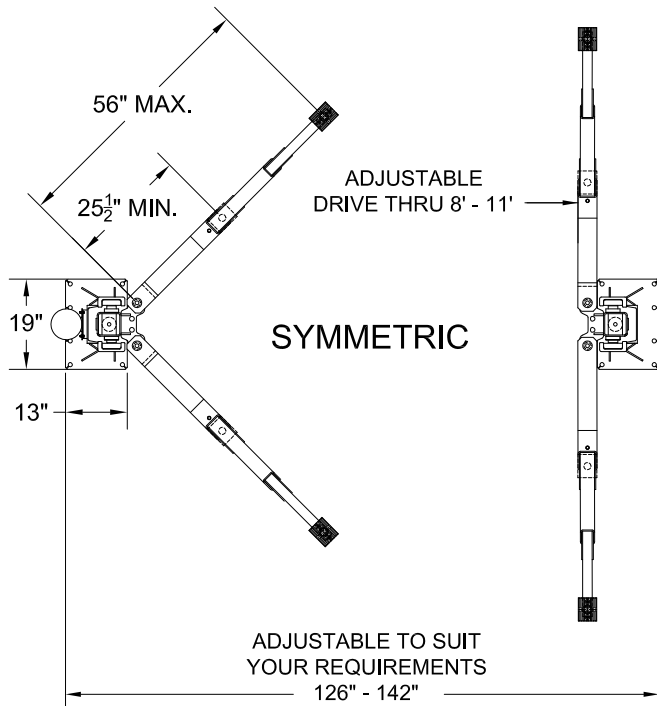

TWO-POST LIFT MODEL: PK10-BH

CAPACITY:.....10,000 LBS
 RISE:..... 82"
 MINIMUM CEILING HEIGHT REQ'D:.....152"
 MOTOR:.....2 HP
 VOLTAGE OPTION 1:..... 208-230V/1PH
 VOLTAGE OPTION 2:..... 230-460V/3PH

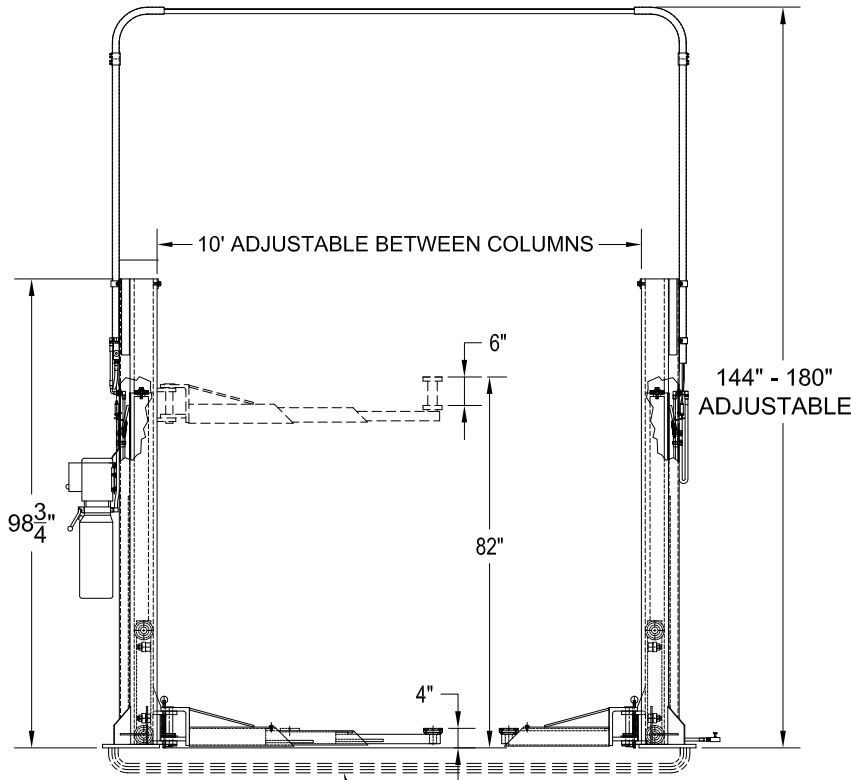

FEATURES:

1. FORK LIFT MAST CHANNEL AND ROLLERS BEARINGS.
2. CLEAR FLOOR FOR EASY ACCESS.
3. NO OVERHEAD BEAM WITH BURIED CONDUIT OPTION.
4. NO EQUALIZING CABLES
5. LOW PROFILE ARMS
6. GEARED ARM RESTRAIN WITH SINGLE POINT LOCK AND RELEASE.
7. THREE STAGE ARMS
8. COMES WITH A SET OF HEIGHT ADAPTERS 3" AND 6" STACK ABLE TO 9".

OPTIONAL LINES ROUTING

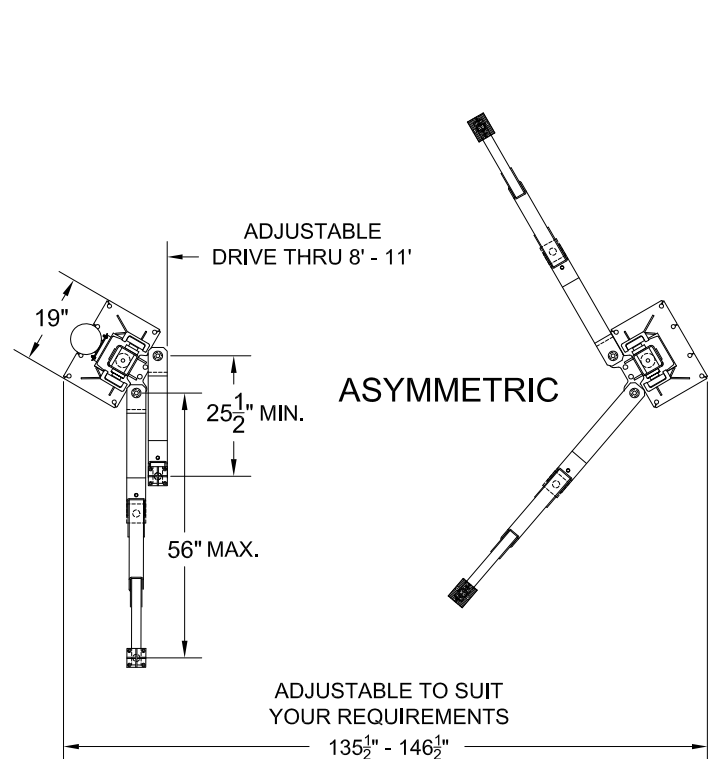
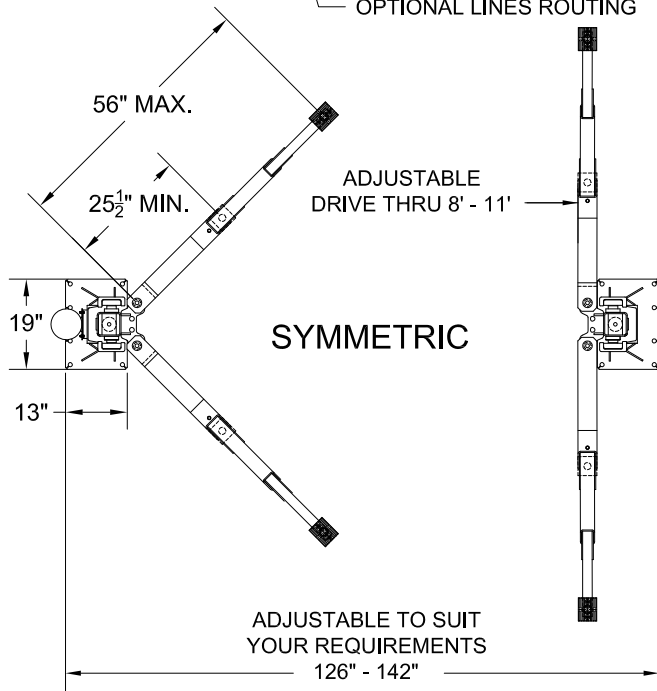

TWO-POST LIFT MODEL: PK12A-B

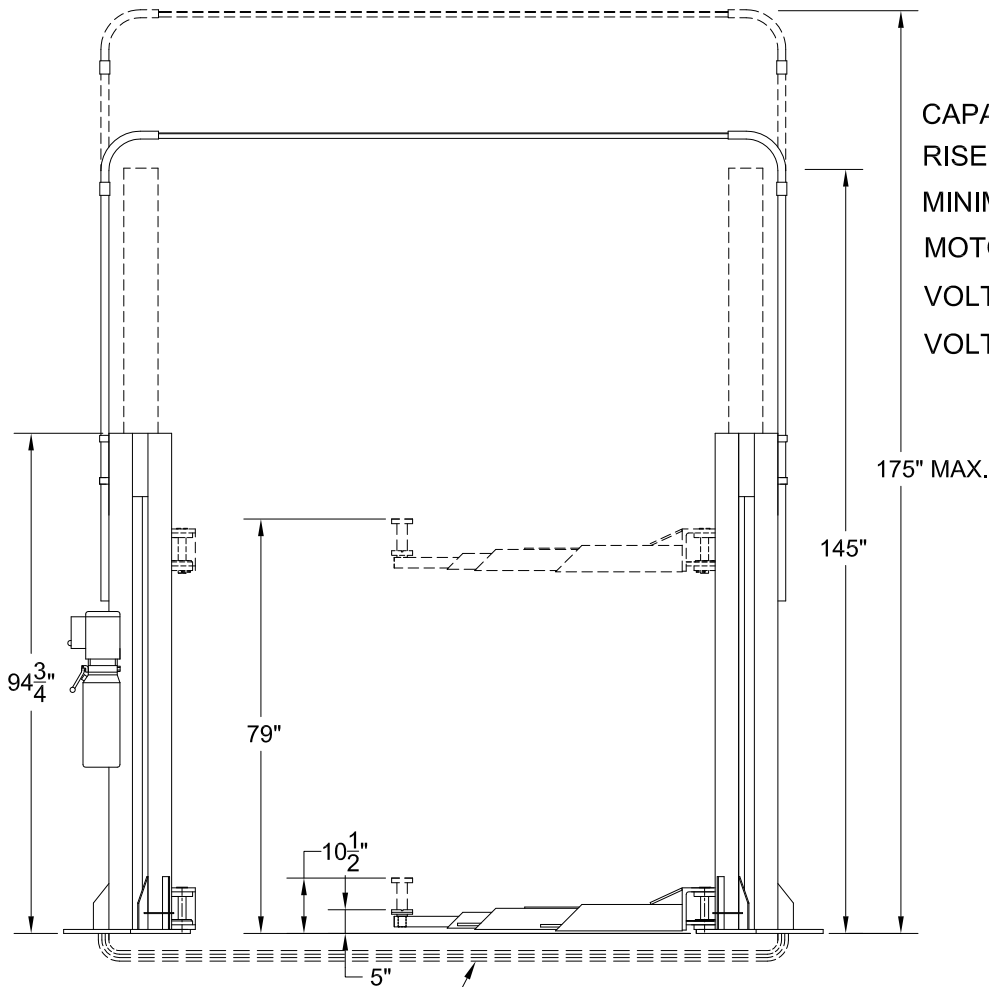

CAPACITY:.....12,000 LBS
 RISE:..... 78"
 MINIMUM CEILING HEIGHT REQ'D:....148"
 MOTOR:.....2 HP
 VOLTAGE OPTION 1:..... 208-230V/1PH
 VOLTAGE OPTION 2:..... 230-460V/3PH

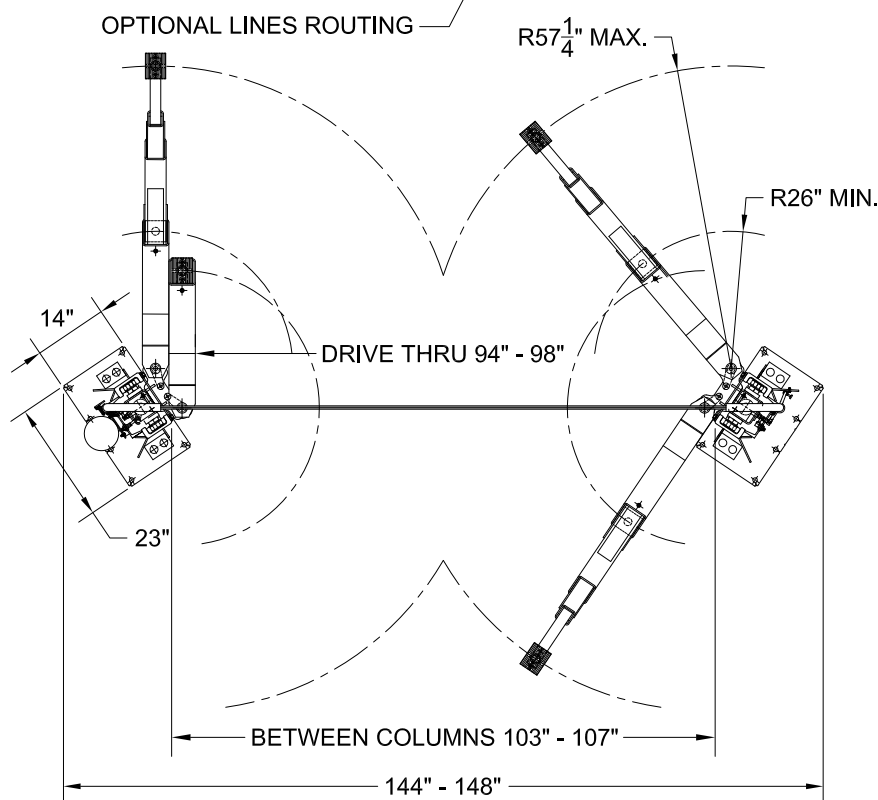

FEATURES:

1. FORK LIFT MAST CHANNEL AND ROLLERS BEARINGS.
2. CLEAR FLOOR FOR EASY ACCESS.
3. NO OVERHEAD BEAM WITH BURIED CONDUIT OPTION.
4. NO EQUALIZING CABLES
5. LOW PROFILE ARMS
6. GEARED ARM RESTRAIN WITH SINGLE POINT LOCK AND RELEASE.
7. THREE STAGE ARMS
8. COMES WITH A SET OF HEIGHT ADAPTERS 3" AND 6" STACK ABLE TO 9".

TWO-POST LIFT MODEL: PK12A-BH

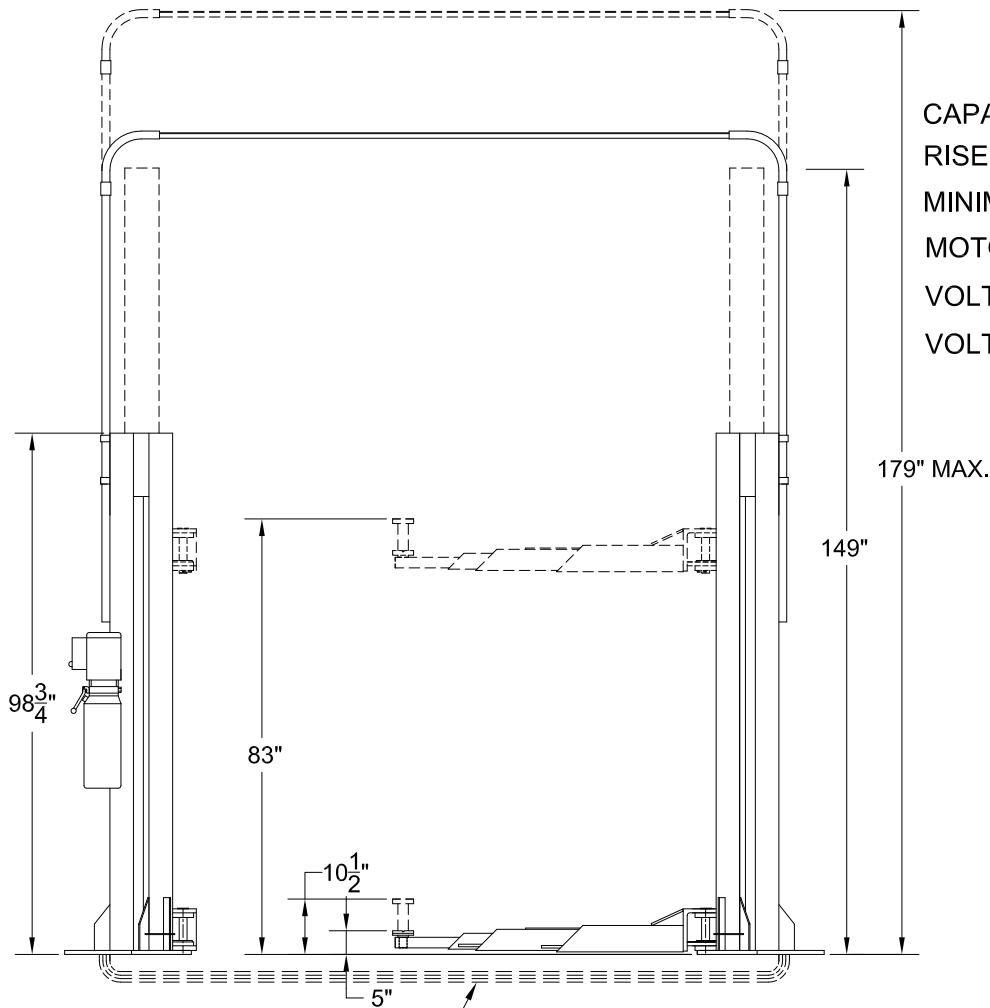

CAPACITY:.....12,000 LBS
 RISE:.....82"
 MINIMUM CEILING HEIGHT REQ'D:....152"
 MOTOR:.....2 HP
 VOLTAGE OPTION 1:.....208-230V/1PH
 VOLTAGE OPTION 2:.....230-460V/3PH

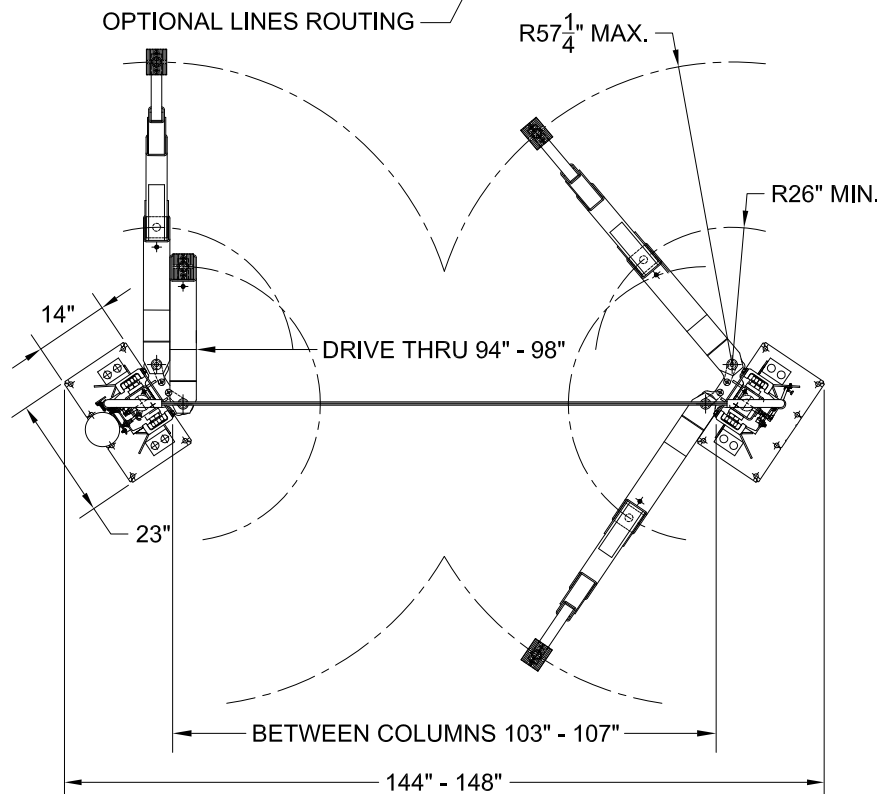

FEATURES:

1. FORK LIFT MAST CHANNEL AND ROLLERS BEARINGS.
2. CLEAR FLOOR FOR EASY ACCESS.
3. NO OVERHEAD BEAM WITH BURIED CONDUIT OPTION.
4. NO EQUALIZING CABLES
5. LOW PROFILE ARMS
6. GEARED ARM RESTRAIN WITH SINGLE POINT LOCK AND RELEASE.
7. THREE STAGE ARMS
8. COMES WITH A SET OF HEIGHT ADAPTERS 3" AND 6" STACK ABLE TO 9".

PKS

DATE
APR.24/2017

DWG
PK12A-BH-SPEC-1

A

TWO-POST LIFT MODEL: PK12-B

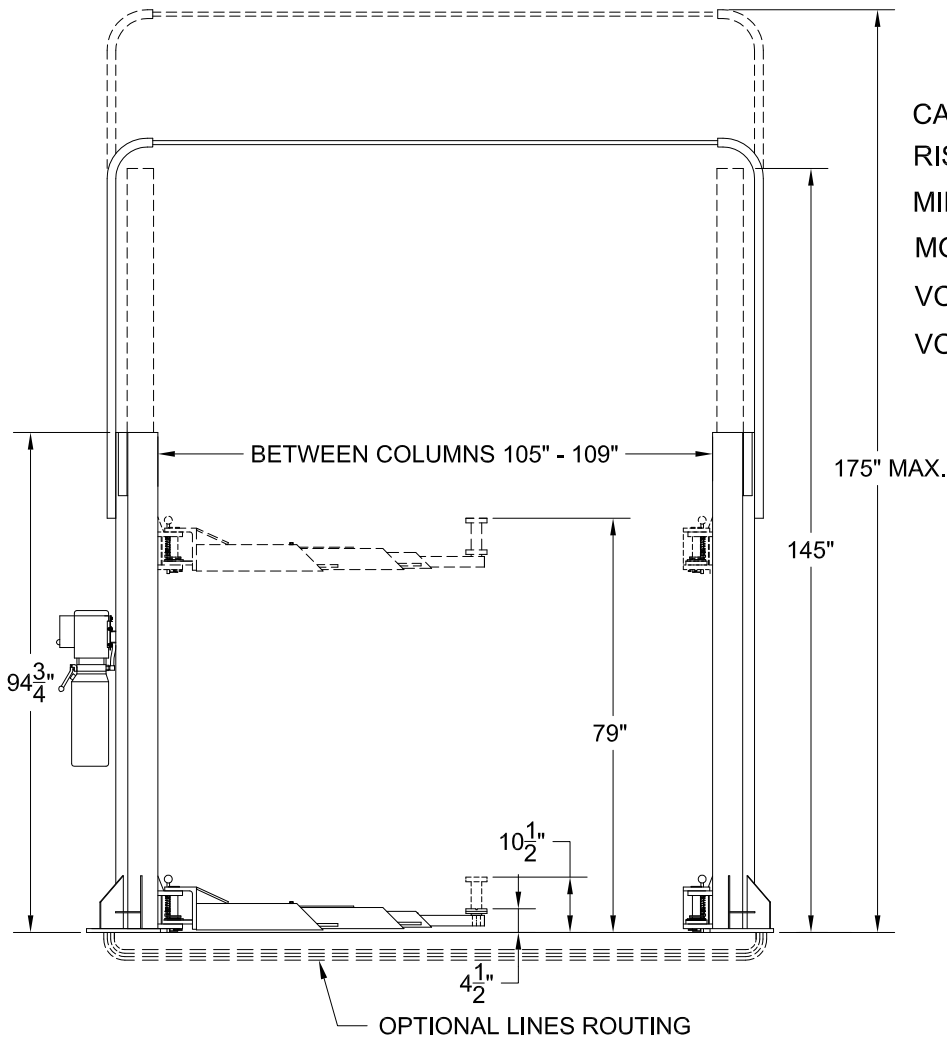

CAPACITY:.....12,000 LBS
 RISE:..... 78"
 MINIMUM CEILING HEIGHT REQ'D:....148"
 MOTOR:.....2 HP
 VOLTAGE OPTION 1:..... 208-230V/1PH
 VOLTAGE OPTION 2:..... 230-460V/3PH

FEATURES:

1. FORK LIFT MAST CHANNEL AND ROLLERS BEARINGS.
2. CLEAR FLOOR FOR EASY ACCESS.
3. NO OVERHEAD BEAM WITH BURIED CONDUIT OPTION.
4. NO EQUALIZING CABLES
5. LOW PROFILE ARMS
6. GEARED ARM RESTRAIN WITH SINGLE POINT LOCK AND RELEASE.
7. THREE STAGE ARMS
8. COMES WITH A SET OF HEIGHT ADAPTERS 3" AND 6" STACK ABLE TO 9".

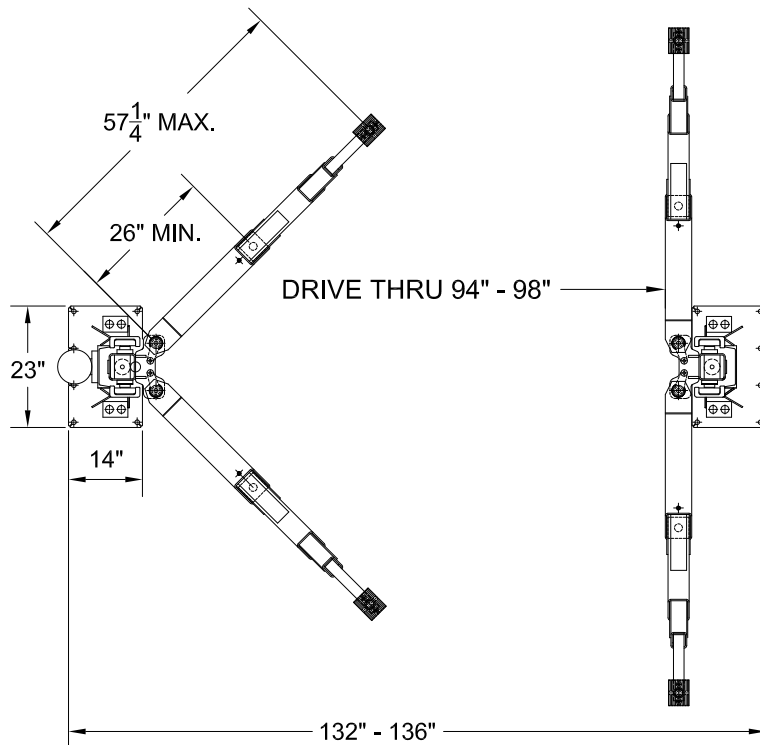

TWO-POST LIFT MODEL: PK12-BH

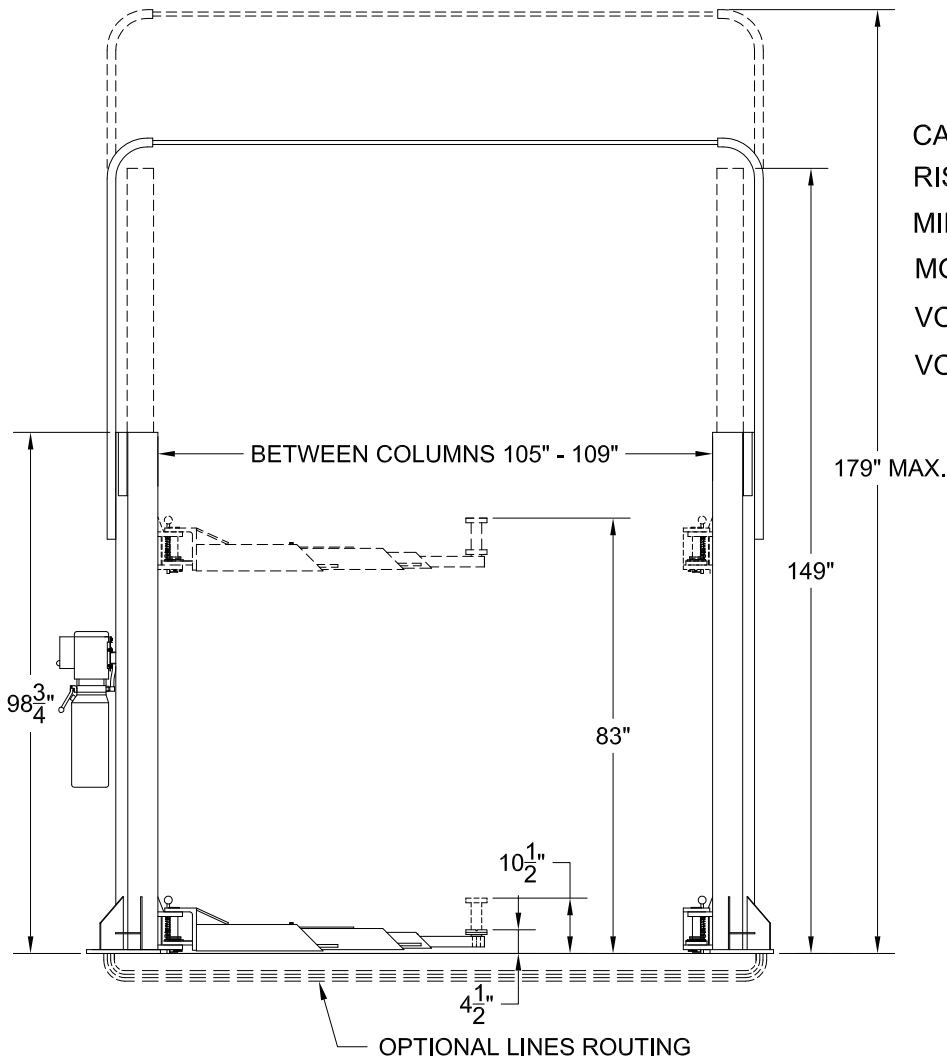

CAPACITY:.....12,000 LBS
 RISE:..... 82"
 MINIMUM CEILING HEIGHT REQ'D:....152"
 MOTOR:.....2 HP
 VOLTAGE OPTION 1:..... 208-230V/1PH
 VOLTAGE OPTION 2:..... 230-460V/3PH

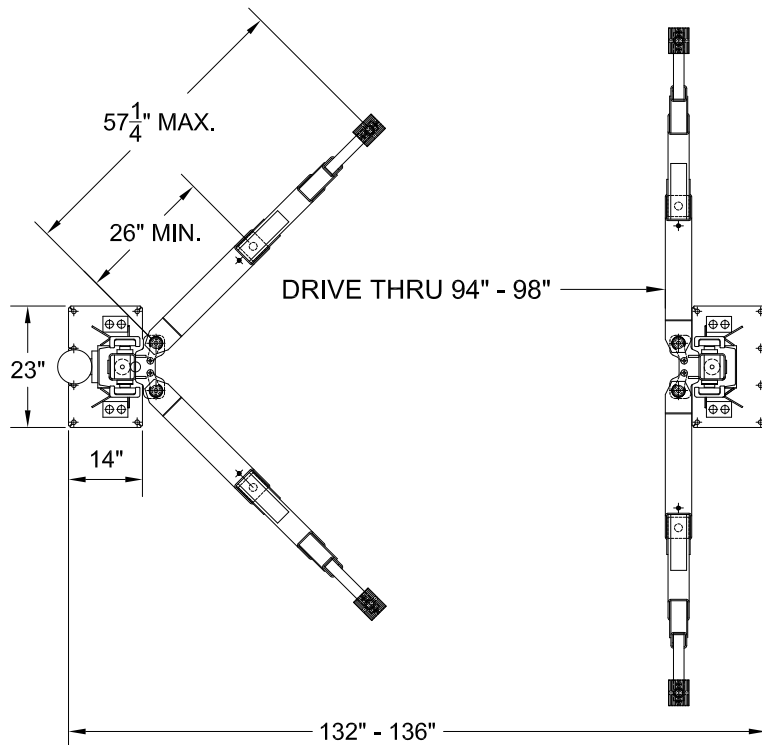

FEATURES:

1. FORK LIFT MAST CHANNEL AND ROLLERS BEARINGS.
2. CLEAR FLOOR FOR EASY ACCESS.
3. NO OVERHEAD BEAM WITH BURIED CONDUIT OPTION.
4. NO EQUALIZING CABLES
5. LOW PROFILE ARMS
6. GEARED ARM RESTRAIN WITH SINGLE POINT LOCK AND RELEASE.
7. THREE STAGE ARMS
8. COMES WITH A SET OF HEIGHT ADAPTERS 3" AND 6" STACK ABLE TO 9".