

CAPACITY	130,000 LBS	INSIDE COLUMN CLEARANCE	144"
FOUR HYDRAULIC CYLINDERS		RUNWAY HEIGHT	13"
FOUR POWER UNITS		RUNWAY WIDTH	32"
PLC BASED CONTROL SYSTEM		OVERALL HEIGHT	109"
SAFETY DEVICES ON EACH COLUMN(MECH.,HYDR.)		OVERALL LIFTING HEIGHT	80"
ELECTRICAL 4 x 3HP (575V)		OVERALL WIDTH	186"
WHEELBASE	32'	OPTIONAL - ROLLING JACKING BEAM	

TITLE	FOUR POST LIFT-130-45	MATERIAL	SPEC.	NOTES	PK130-4
P K S		MAY.26/2006	DWG	PK130-4-45	A

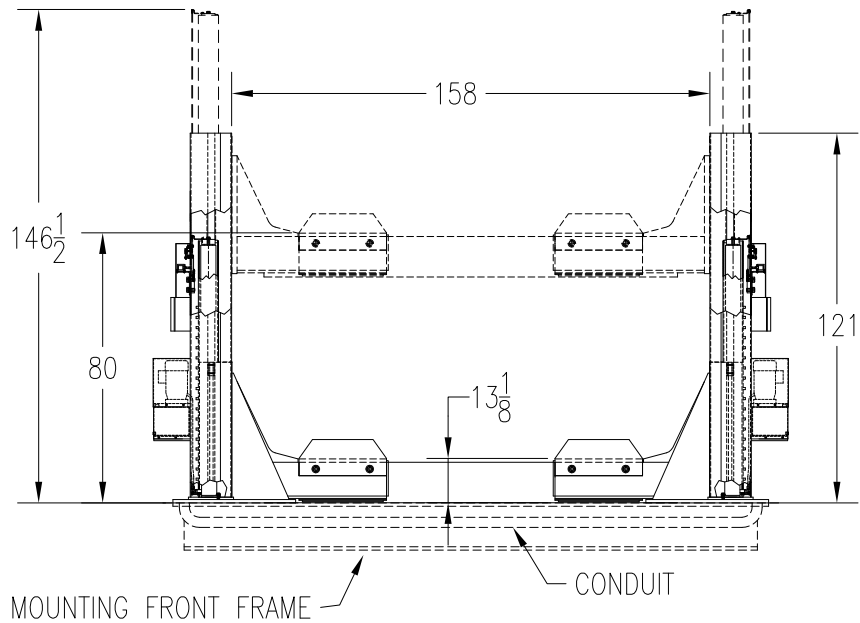
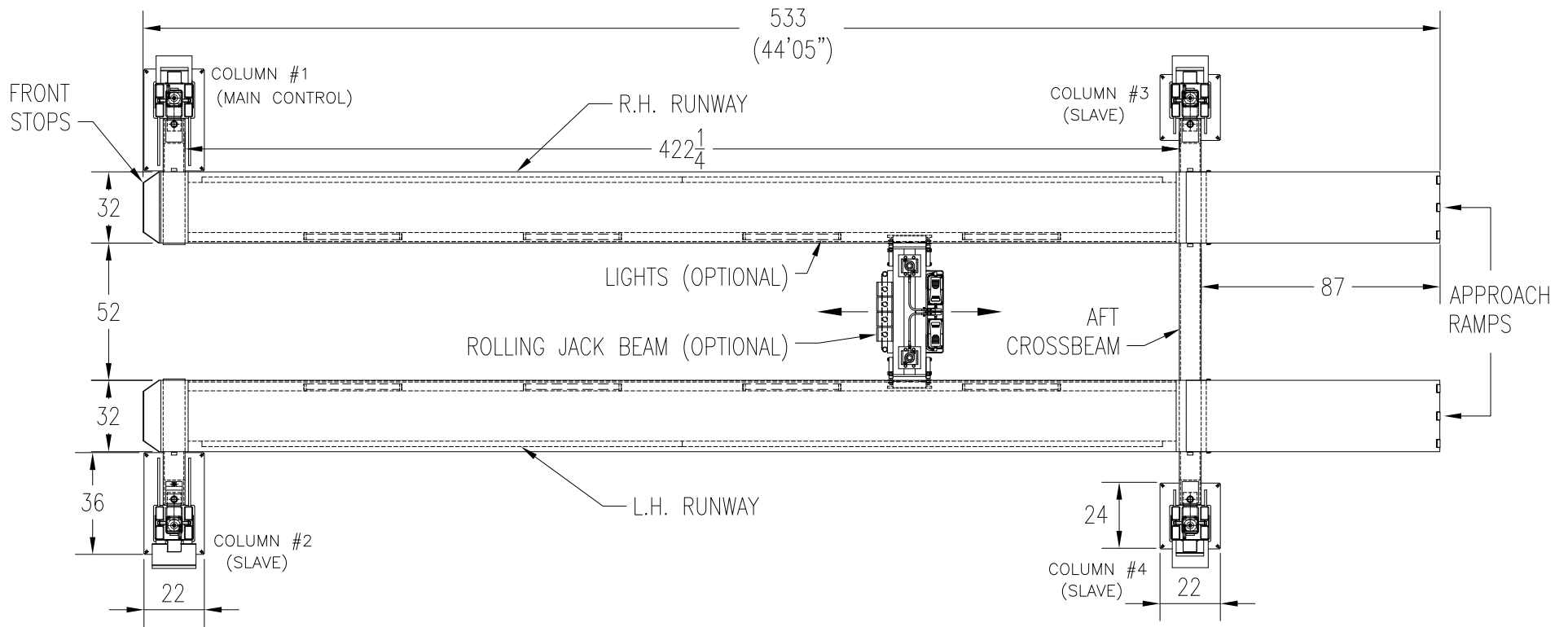

CAPACITY	130,000 LBS	INSIDE COLUMN CLEARANCE	158"
FOUR HYDRAULIC CYLINDERS		RUNWAY HEIGHT	13"
FOUR POWER UNITS		RUNWAY WIDTH	32"
PLC BASED CONTROL SYSTEM		OVERALL HEIGHT	121"
SAFETY DEVICES ON EACH COLUMN(MECH.,HYDR.)		OVERALL LIFTING HEIGHT	80"
ELECTRICAL 4 x 3HP (575V)		OVERALL WIDTH	194"
WHEELBASE	32'	OPTIONAL - ROLLING JACKING BEAM	

TITLE	MATERIAL	NOTES
4 POST LIFT 130.35 OPEN FRONT BEAM	SPEC.	PK130E-4-OFB
P K S	DWG	PK130E40FB-01
JULY 15/2011		A