

# MOBILE TRUCK LIFT

## MODEL: PKMR-24-AH

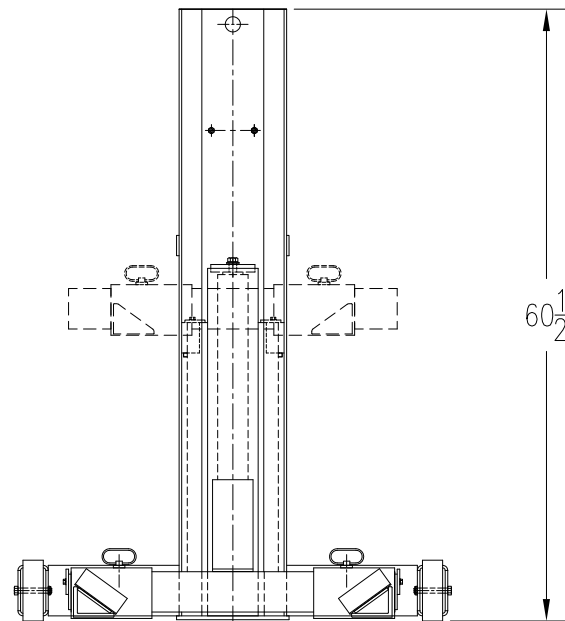
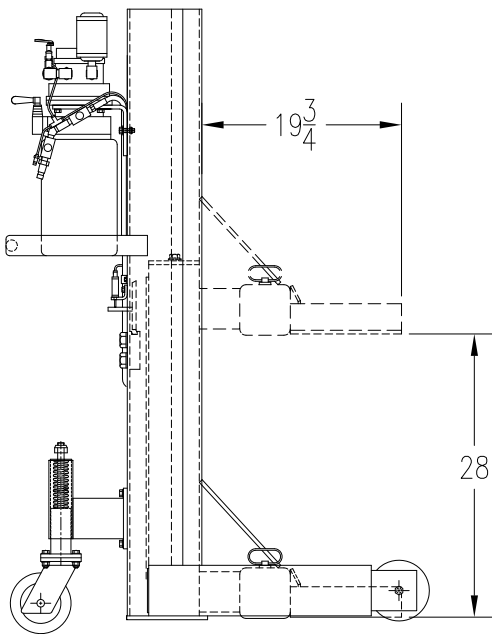
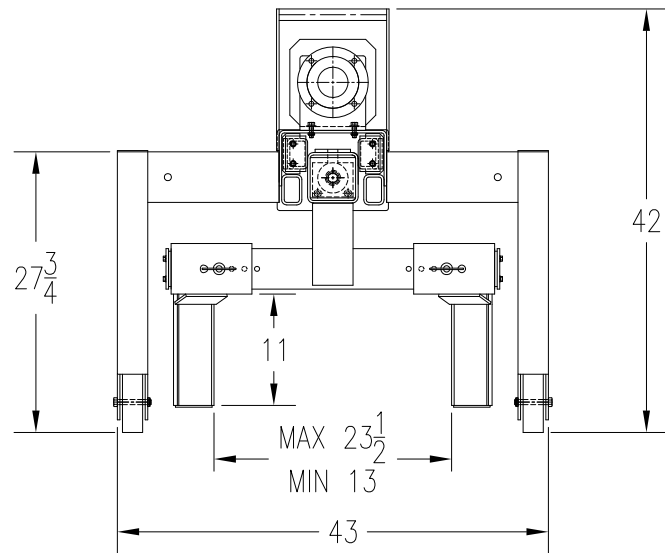

CAPACITY PER COLUMN - 12,000 lbs

LIFTING HEIGHT UP TO 28"

AIR/HYDRAULIC SYSTEM

AIR PRESSURE REQUIRED 90 PSI

AUTOMATIC MULTI-POSITION MECHANICAL LOCK

SPRING LOADED THIRD WHEEL

COLUMN WEIGHT 450 LBS

ADJUSTABLE FORKS, TIRES 20" TO 48" DIAMETER

# MOBILE TRUCK LIFT

## MODEL: PKMR-36-AH

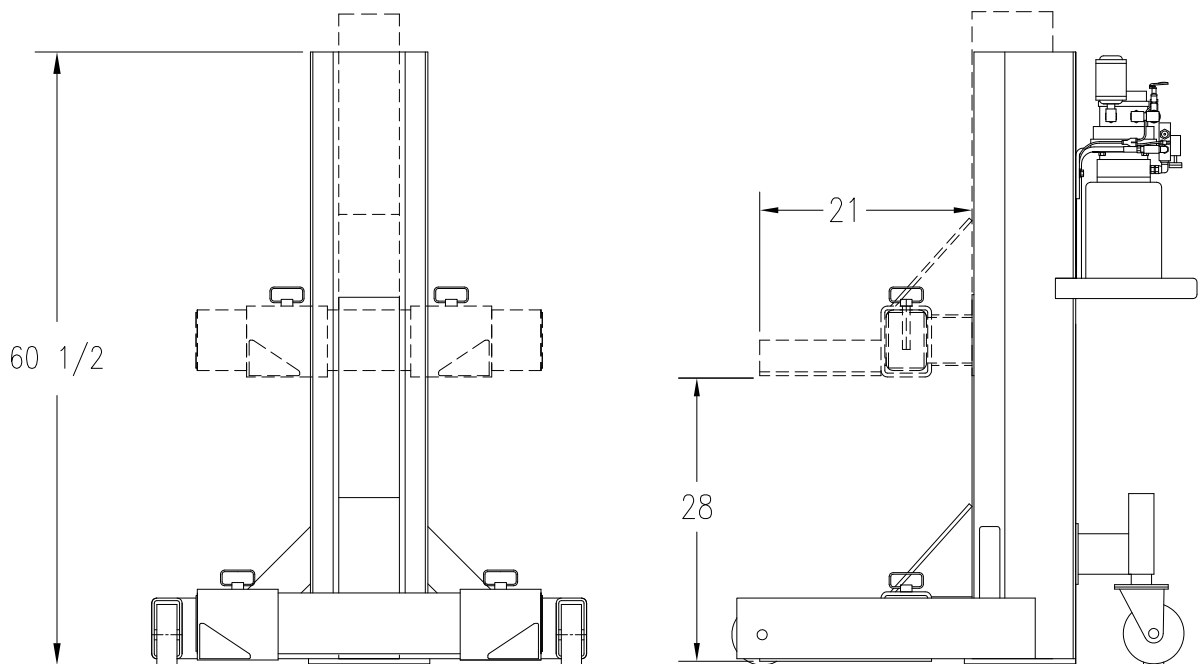
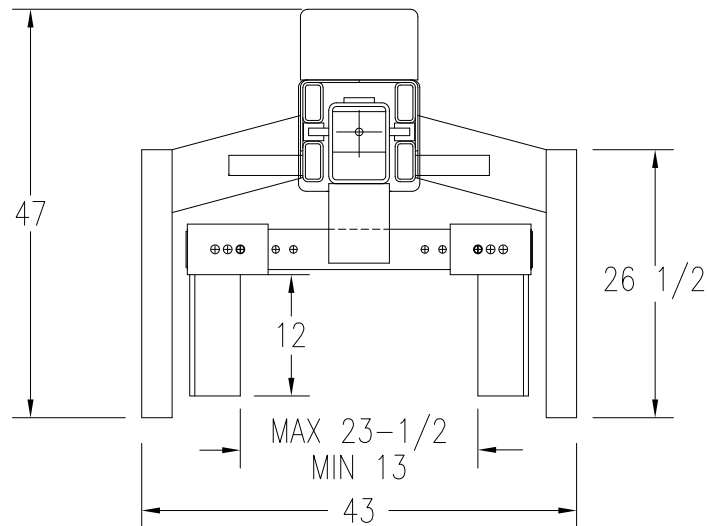

CAPACITY PER COLUMN - 18,000 lbs

LIFTING HEIGHT UP TO 28"

AIR/HYDRAULIC SYSTEM

AIR PRESSURE REQUIRED 90 PSI

AUTOMATIC MULTI-POSITION MECHANICAL LOCK

SPRING LOADED THIRD WHEEL

COLUMN WEIGHT 580 LBS

ADJUSTABLE FORKS ( 13" TO 23-1/2" INSIDE)

# MOBILE TRUCK LIFT MODEL: PKMR-48-AH

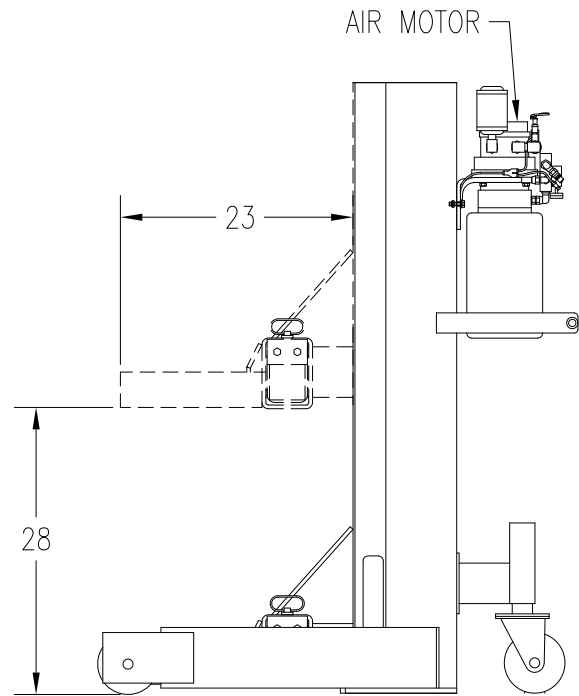
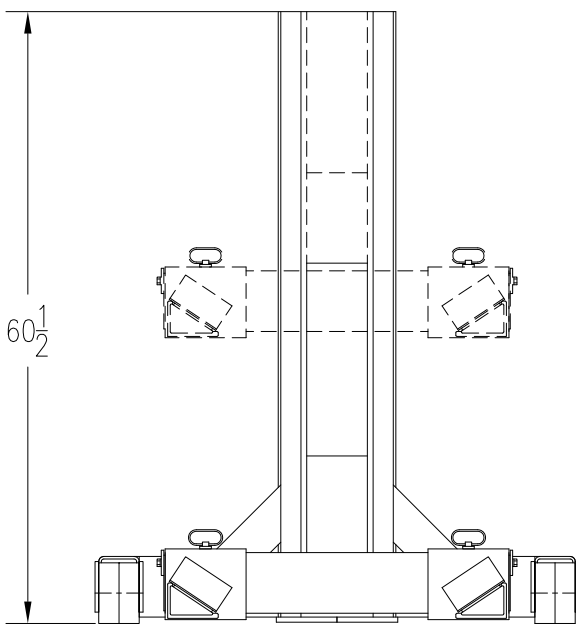
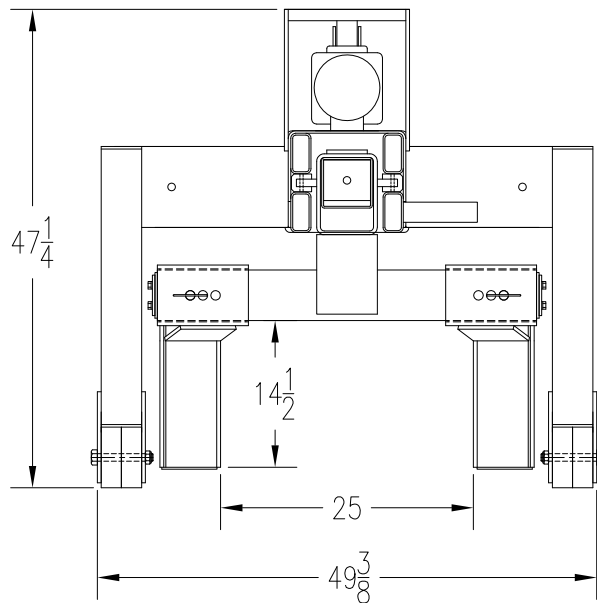

CAPACITY PER COLUMN - 24,000 lbs

LIFTING HEIGHT UP TO 28"

AIR/HYDRAULIC SYSTEM

AIR PRESSURE REQUIRED 90 PSI

AUTOMATIC MULTI-POSITION MECHANICAL LOCK

SPRING LOADED THIRD WHEEL

COLUMN WEIGHT 650 LBS