

CAPACITY PER COLUMN - 12,000 lbs
 LIFTING HEIGHT UP TO 67"
 LIFTING SPEED - 46 seconds
 ELECTRIC/HYDRAULIC SYSTEM
 AUTOMATIC MULTI-POSITION MECHANICAL LOCK
 HYD. OPERATED THIRD WHEEL
 ADJUSTABLE FORKS (13" TO 23-1/2" INSIDE)

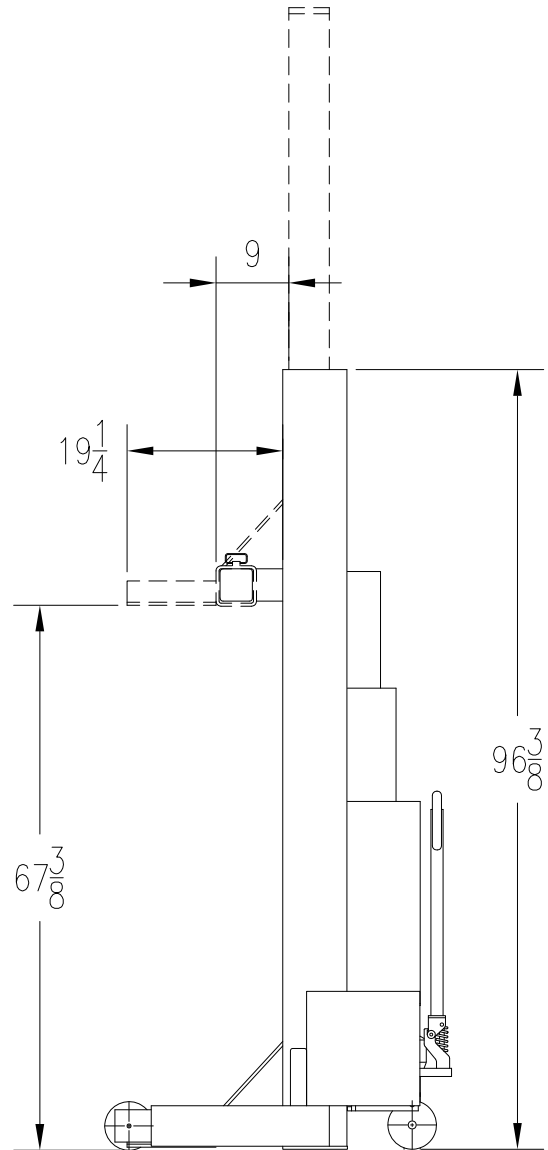

MOBILE LIFT COLUMN
 MODEL: PKMC12-BO

P	K	S	JULY 14/2008	PKMC12-BO	A
---	---	---	--------------	-----------	---

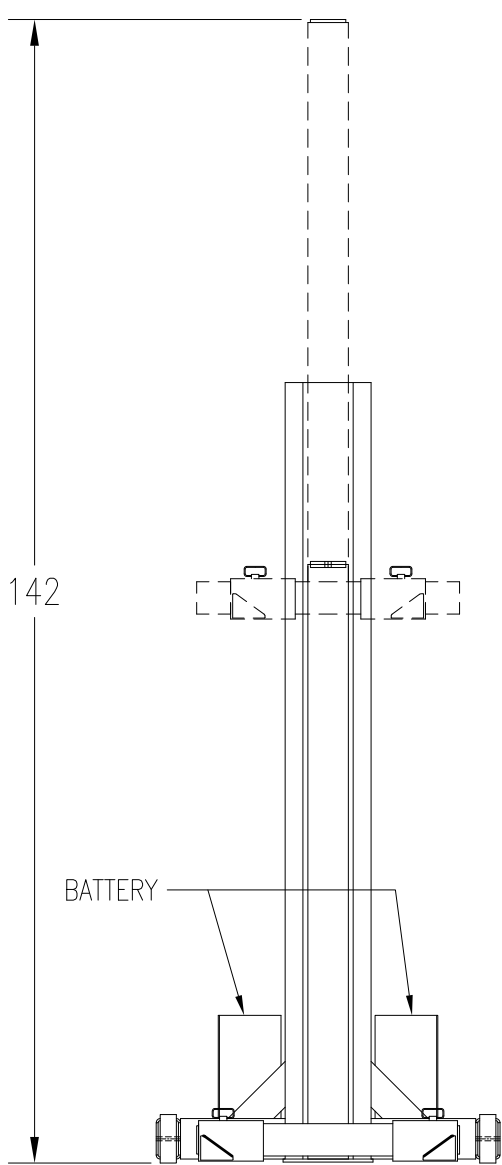
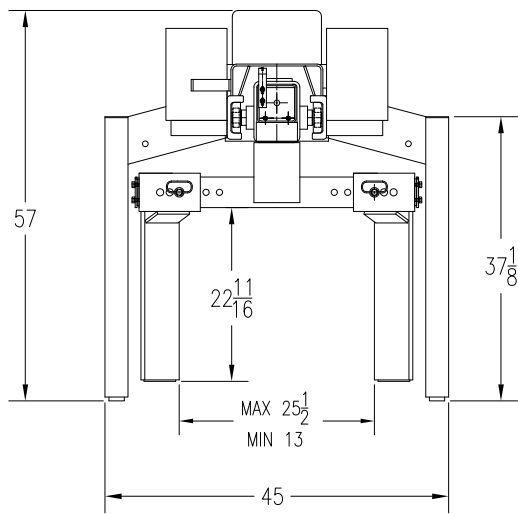

CAPACITY PER COLUMN - 16,000 lbs
 LIFTING HEIGHT UP TO 69"
 LIFTING SPEED - 69 seconds
 24 VDC ELECTRIC/HYDRAULIC SYSTEM
 AUTOMATIC MULTI-POSITION MECHANICAL LOCK
 HYD. OPERATED THIRD WHEEL
 ADJUSTABLE FORKS (13" TO 25-1/2" INSIDE)
 STEEL ROLLERS, 7/8" THICK CHANNEL

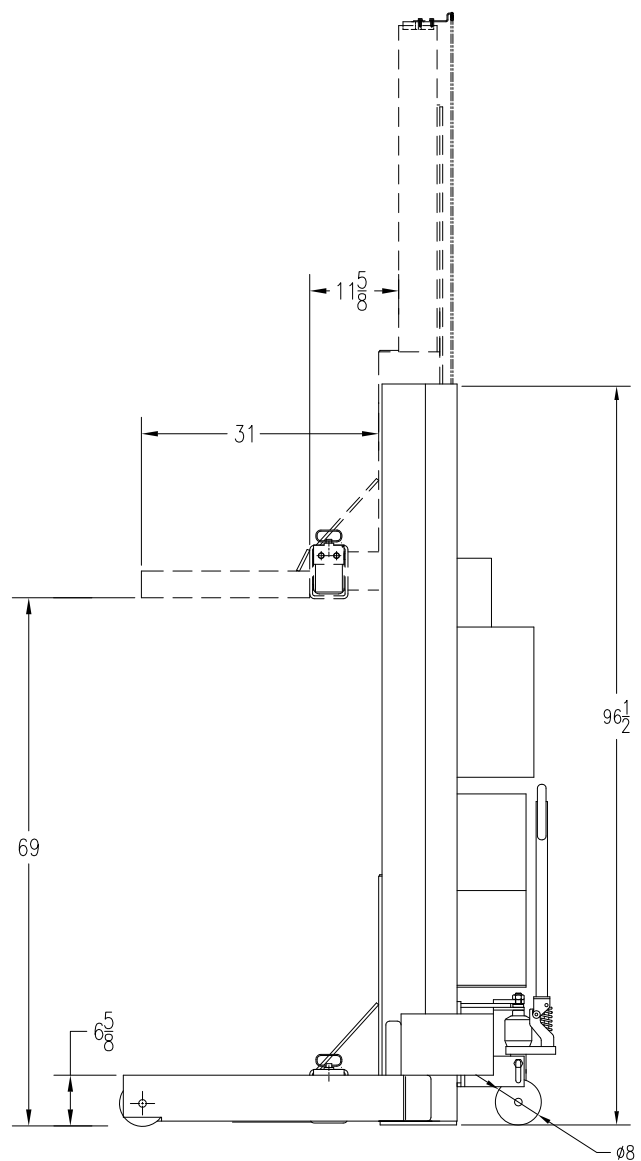
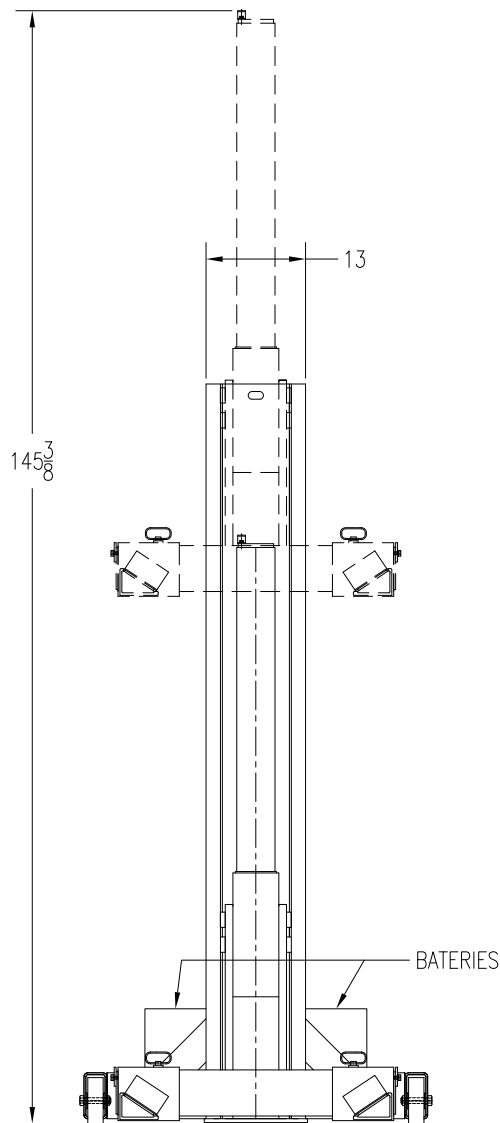

MOBILE LIFT COLUMN
 MODEL: PKMC-16-B0

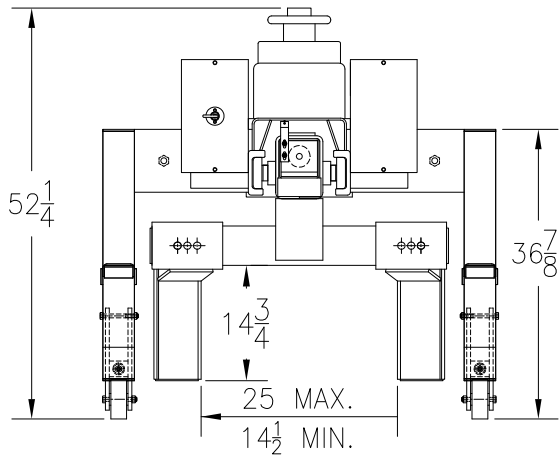

CAPACITY PER COLUMN - 24,000 lbs
 LIFTING HEIGHT UP TO 69"
 LIFTING SPEED - 90 seconds
 ELECTRIC/HYDRAULIC SYSTEM
 AUTOMATIC MULTI-POSITION MECHANICAL LOCK
 HYD. OPERATED THIRD WHEEL
 ADJUSTABLE FORKS (14-1/2" TO 25" INSIDE)

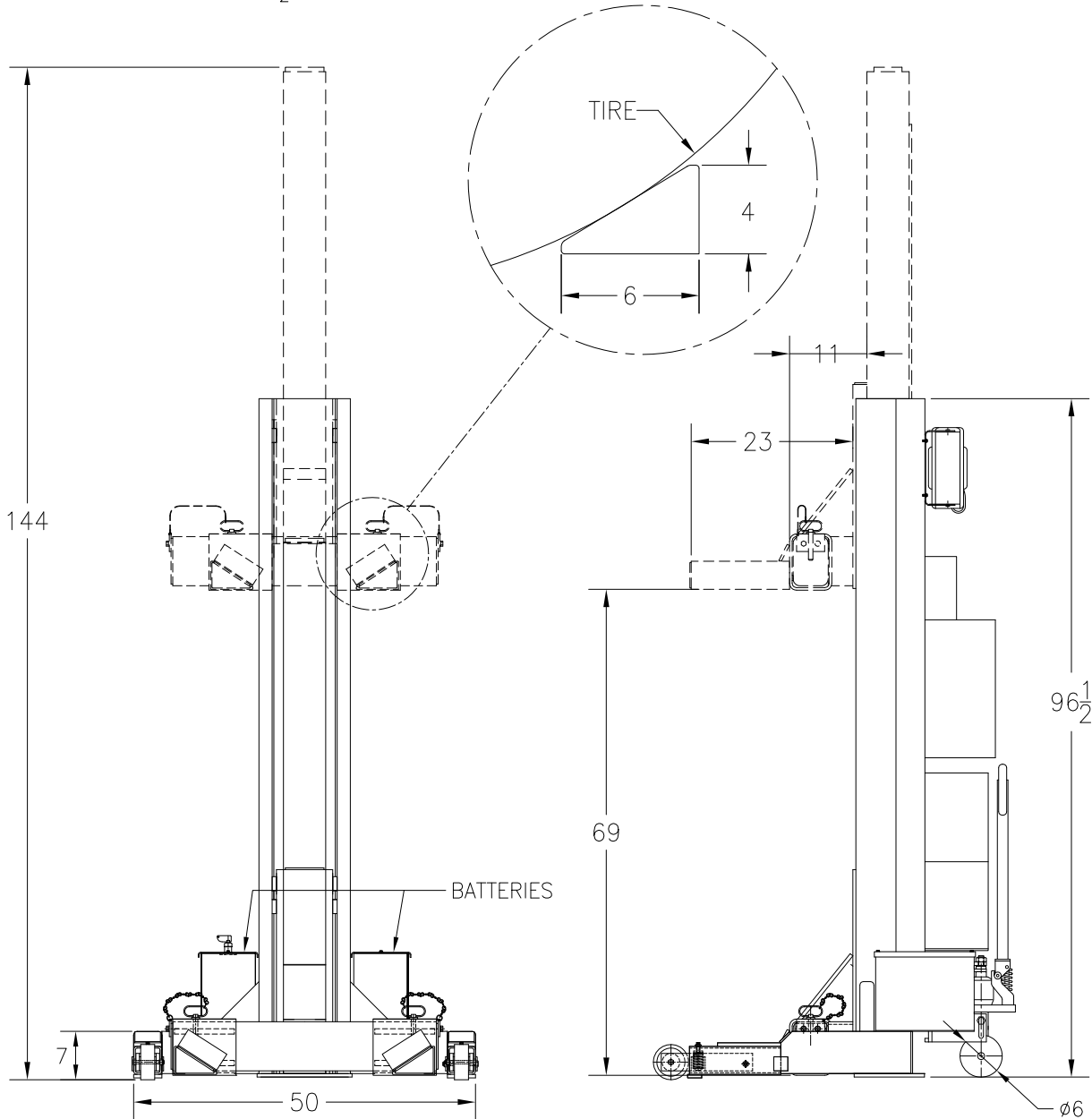

MOBILE LIFT COLUMN
 MODEL: PKMC24-BO

DWN. JK	P	K	S	JULY 22/2014	PKMC24B0.01	A
APPR. KK						