

CAPACITY PER COLUMN - 16,000 lbs
 LIFTING HEIGHT UP TO 69"
 LIFTING SPEED - 69 seconds
 ELECTRIC/HYDRAULIC SYSTEM
 AUTOMATIC MULTI-POSITION MECHANICAL LOCK
 HYD. OPERATED THIRD WHEEL
 ADJUSTABLE FORKS (13" TO 25-1/2" INSIDE)
 STEEL ROLLERS, 7/8" THICK CHANNEL

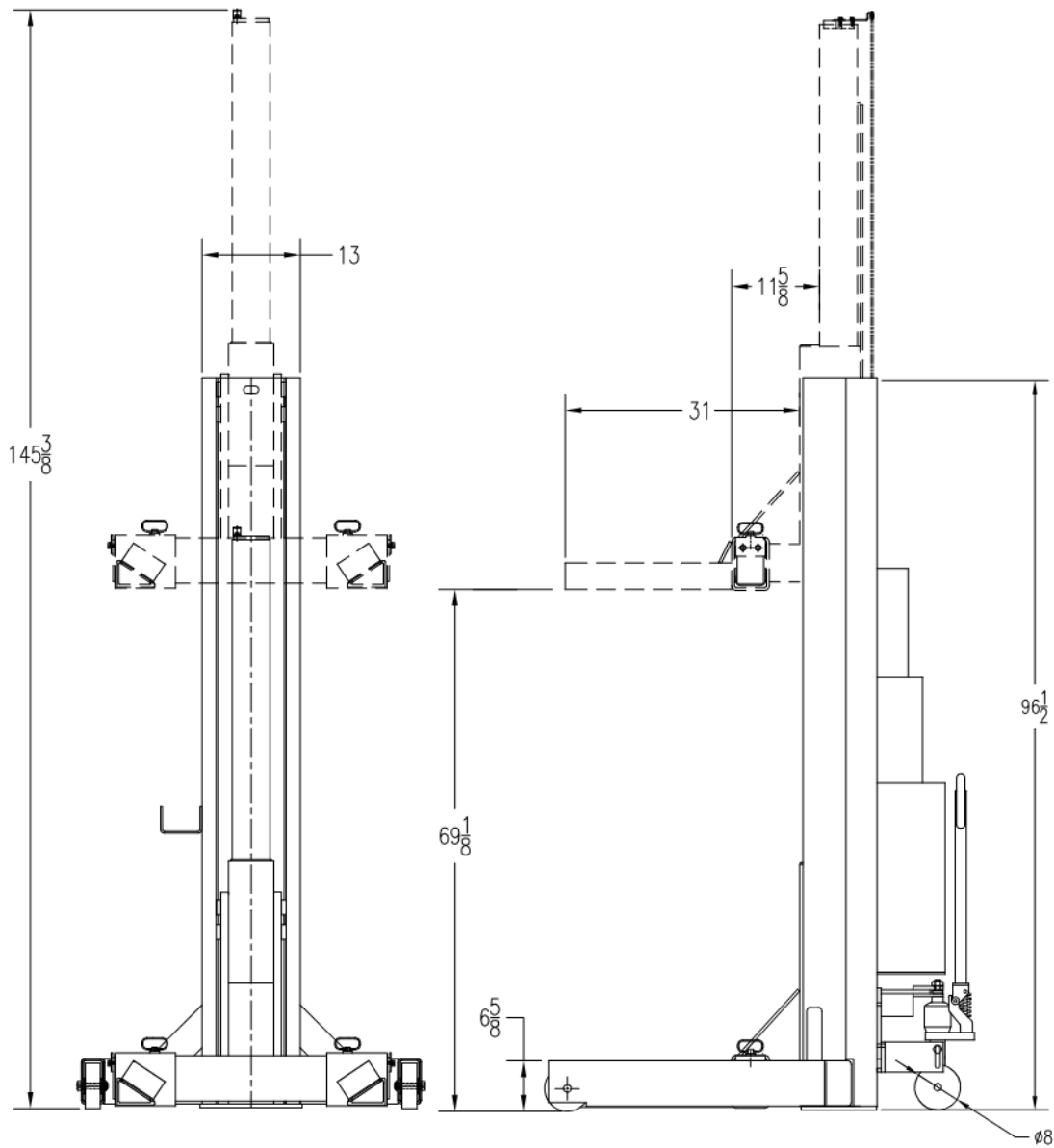

MOBILE LIFT COLUMN
 MODEL:PKMC16-PC

DWN. JK	P	K	S	MAY 28/2013	PKMC16-PC-69	A
APPR. KK						

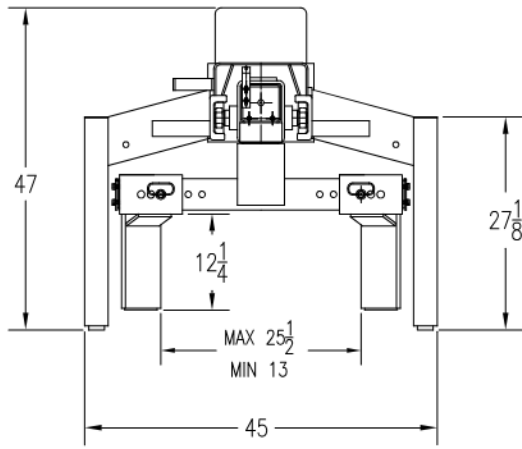

CAPACITY PER COLUMN - 18,000 lbs
 LIFTING HEIGHT UP TO 69"
 LIFTING SPEED - 69 seconds
 ELECTRIC/HYDRAULIC SYSTEM
 AUTOMATIC MULTI-POSITION MECHANICAL LOCK
 HYD. OPERATED THIRD WHEEL
 ADJUSTABLE FORKS (13" TO 25-1/2" INSIDE)
 STEEL ROLLERS, 7/8" THICK CHANNEL

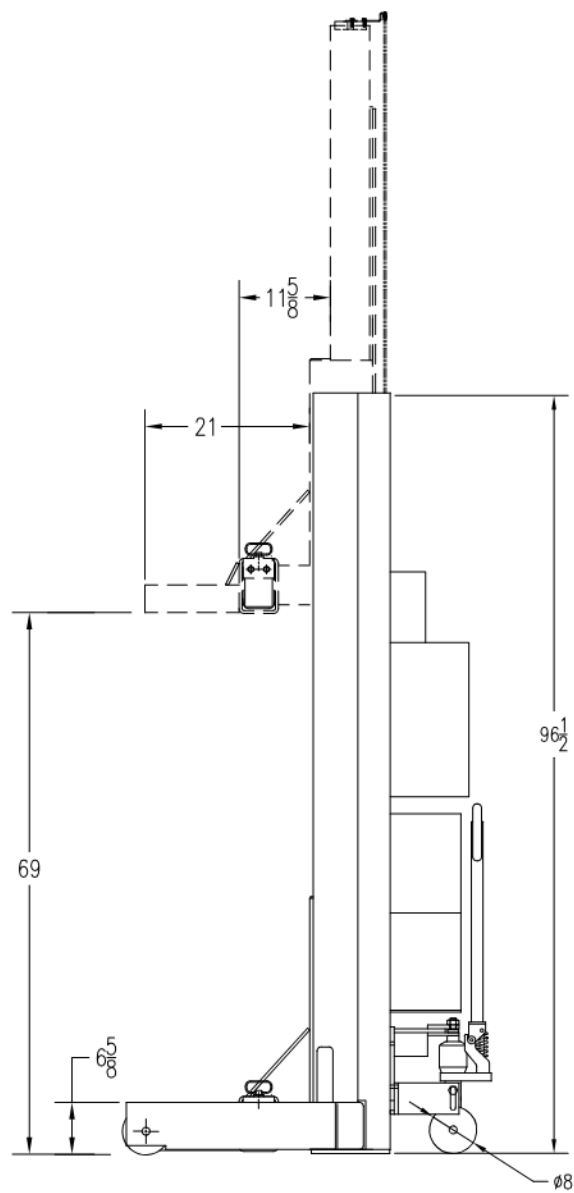
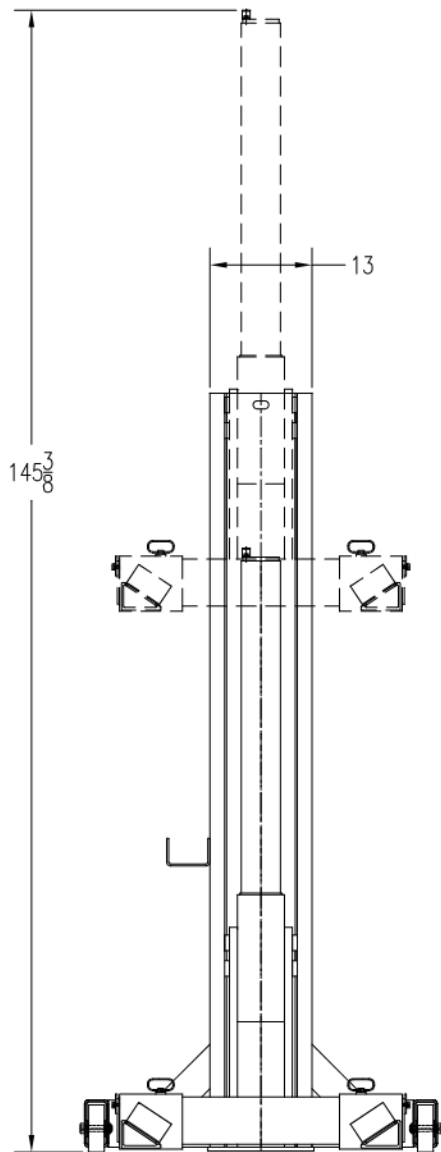

MOBILE LIFT COLUMN
 MODEL: PKMC18-PC

DWN.
 KK
 APPR.
 KK

P

K

S

MAR.01/2005

PKMC18-69-PC

A

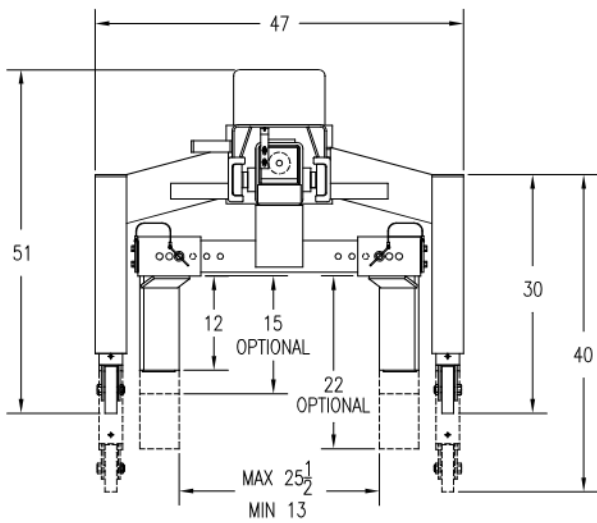

CAPACITY PER COLUMN - 20,000 lbs
 LIFTING HEIGHT UP TO 67"
 LIFTING SPEED - 66 seconds
 ELECTRIC/HYDRAULIC SYSTEM
 AUTOMATIC MULTI-POSITION MECHANICAL LOCK
 HYD. OPERATED THIRD WHEEL
 ADJUSTABLE FORKS (13" TO 25-1/2" INSIDE)
 SPRING LOADED FRONT WHEELS

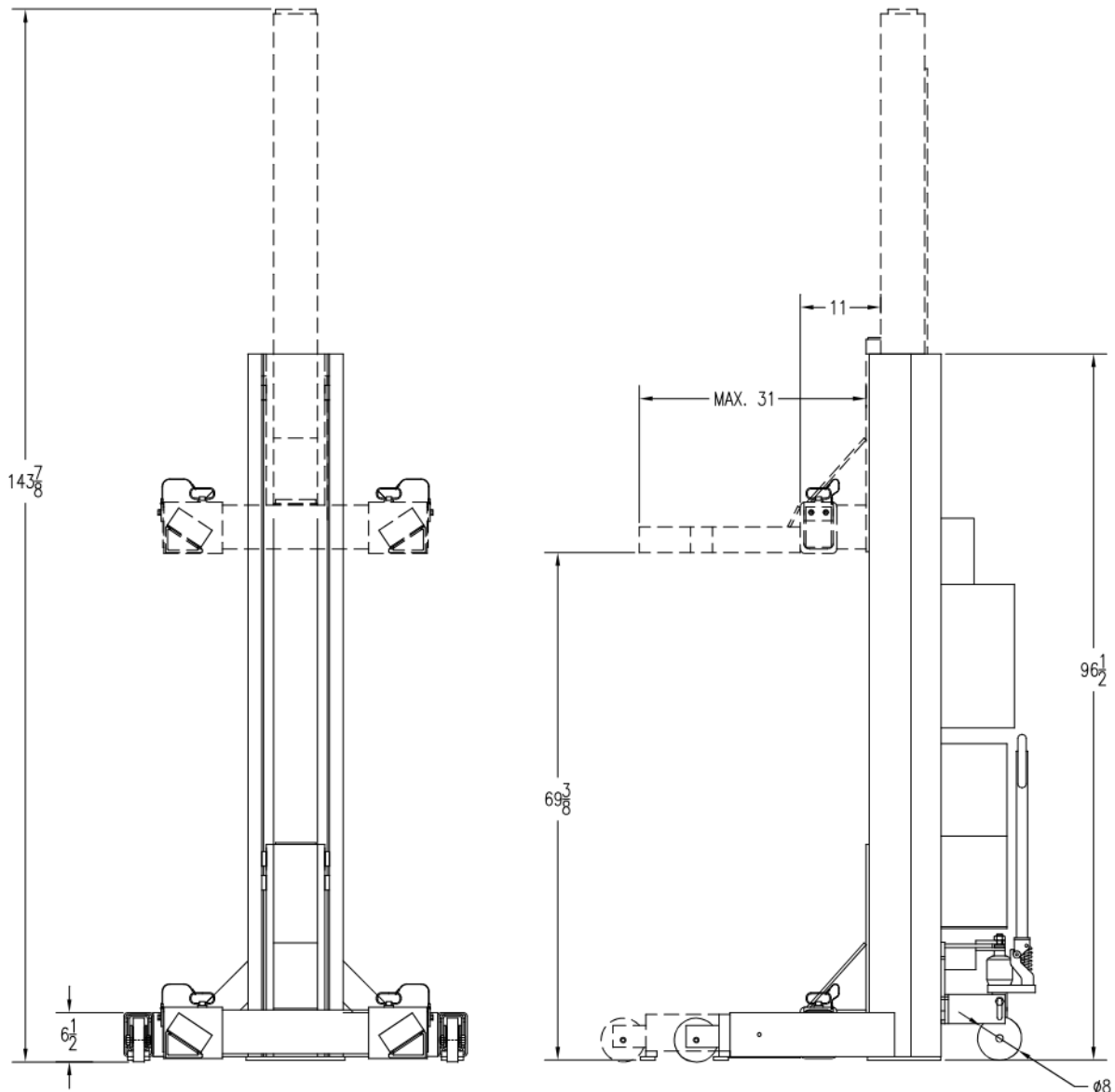

MOBILE LIFT COLUMN
 MODEL: PKSM20-PC

DWN. JK	P	K	S	MAY 07/2013	PKSM20-PC	A
APPR. KK						

