

# MOBILE TRUCK LIFT

## MODEL: PKMR-24-EH

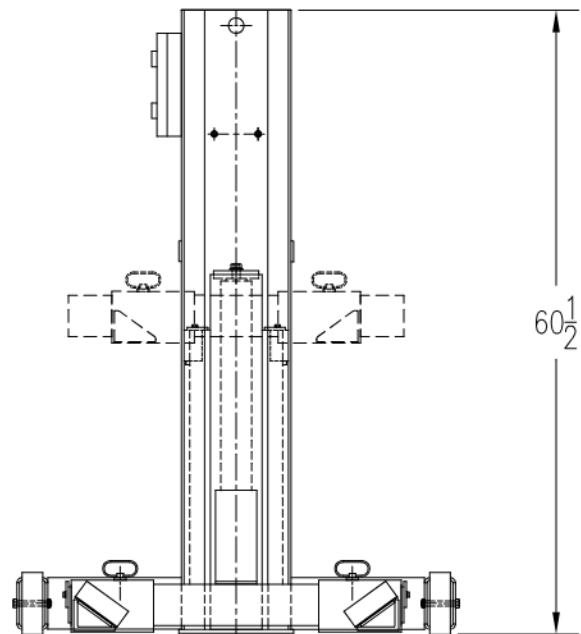

- CAPACITY PER COLUMN - 12,000 lbs
- LIFTING HEIGHT UP TO 28"
- ELECTRIC/HYDRAULIC SYSTEM
- AUTOMATIC MULTI-POSITION MECHANICAL LOCK
- SPRING LOADED THIRD WHEEL
- COLUMN WEIGHT 450 LBS
- ADJUSTABLE FORKS, TIRES 20" TO 48" DIAMETER

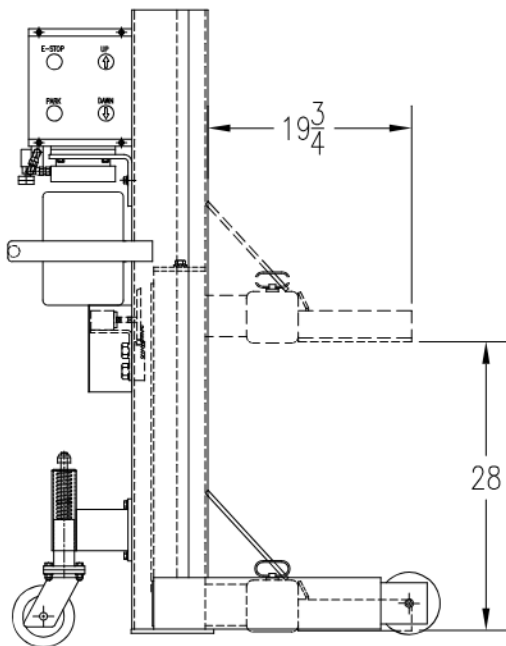
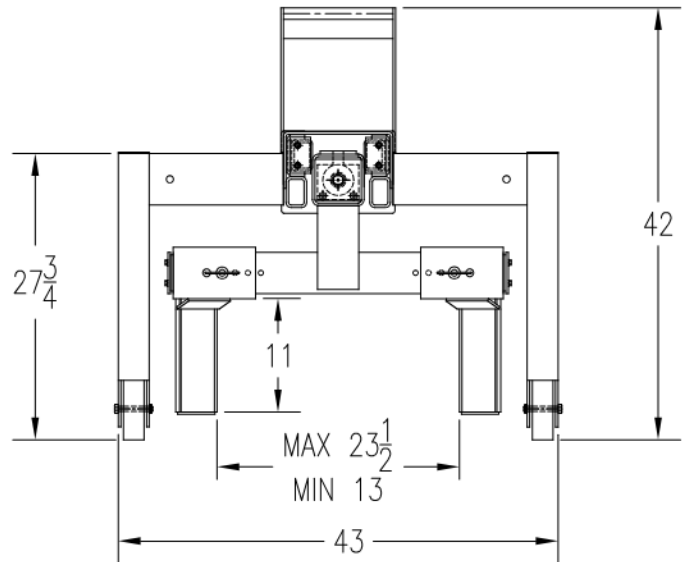

# MOBILE TRUCK LIFT MODEL: PKMR-36-EH

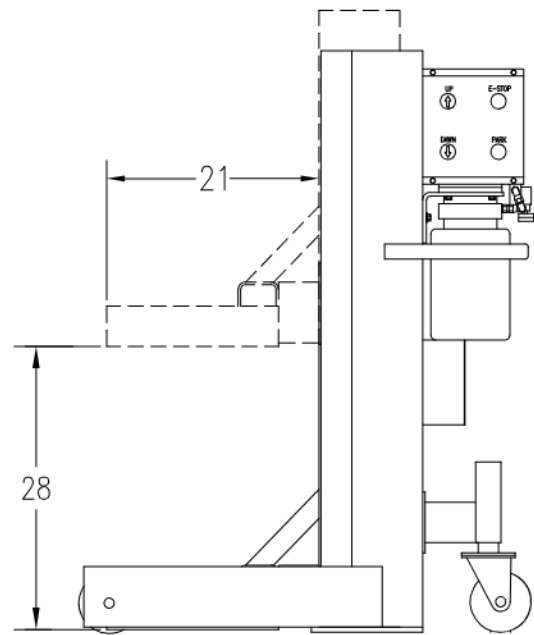
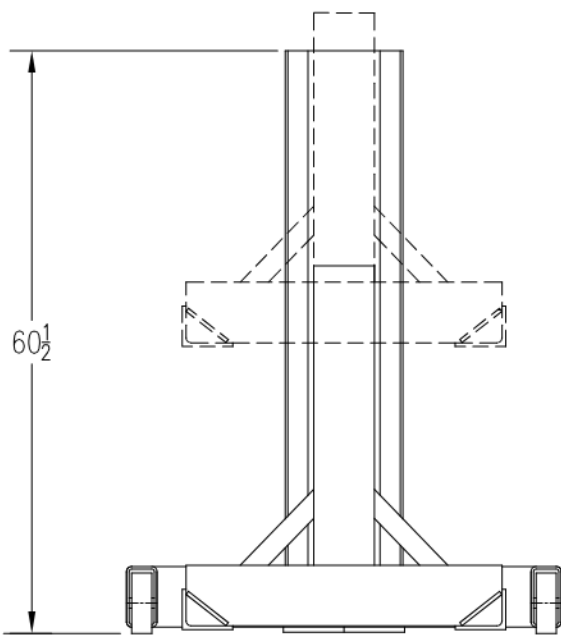
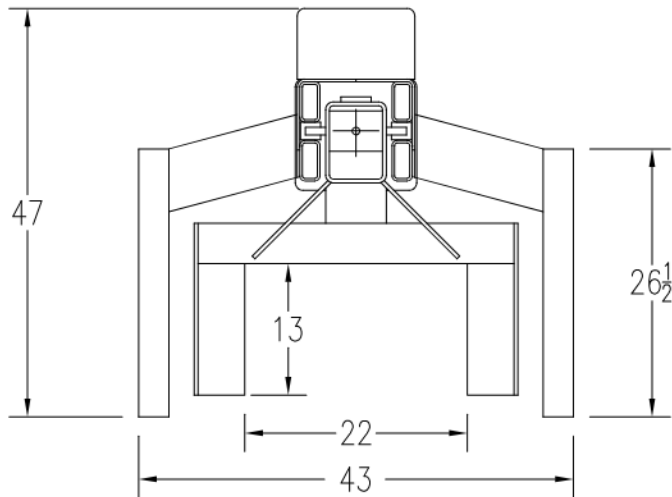

CAPACITY PER COLUMN - 18,000 lbs  
LIFTING HEIGHT UP TO 28"  
EL./HYDRAULIC SYSTEM  
AUTOMATIC MULTI-POSITION  
SPRING LOADED THIRD WHEEL MECHANICAL LOCK  
COLUMN WEIGHT 580 LBS  
ADJUSTABLE FORKS ( 13" TO 23-1/2" INSIDE)

# MOBILE TRUCK LIFT MODEL: PKMR-48-EH

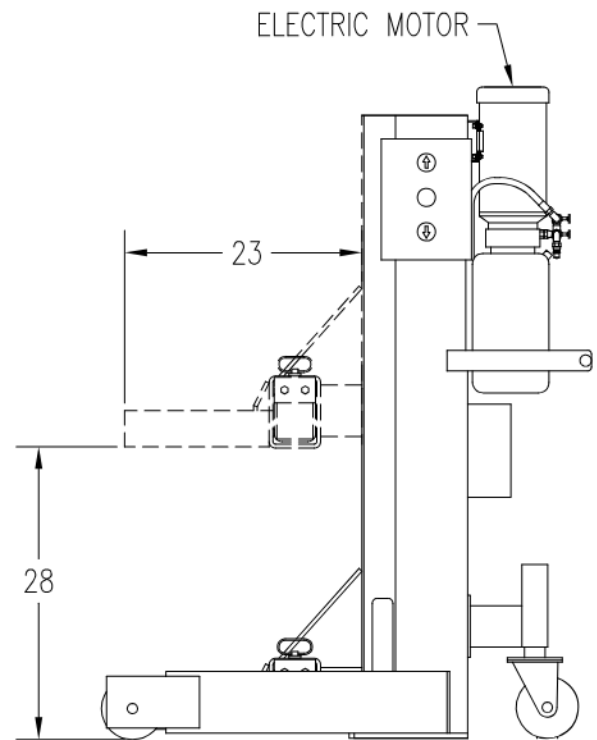
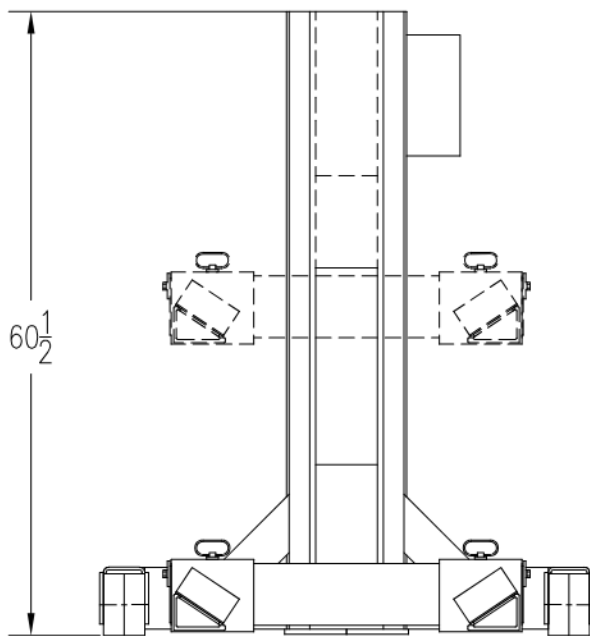
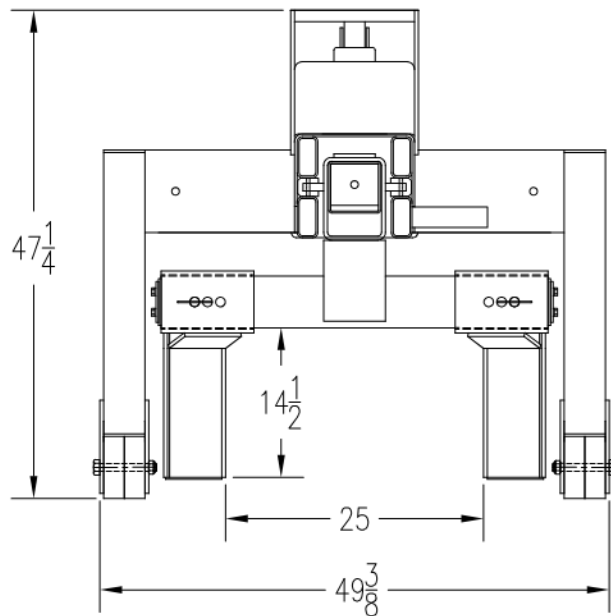

CAPACITY PER COLUMN - 24,000 lbs

LIFTING HEIGHT UP TO 28"

ELECTRI/HYDRAULIC SYSTEM

AUTOMATIC MULTI-POSITION MECHANICAL LOCK

SPRING LOADED THIRD WHEEL

COLUMN WEIGHT 650 LBS